

v-protect

fiber optic splice protectors

Aluminium, crimp fiber
optic splice protectors

Series ANT

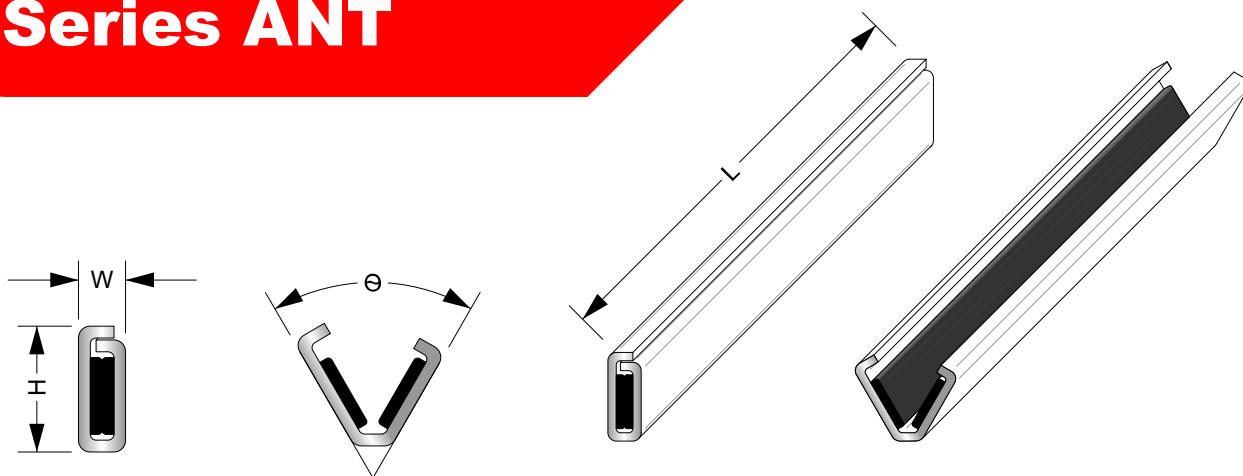

Part No.	W	H	L	θ
ANT-30-00	1,2	3,3	30	52°

All dimensions in mm. Other lengths are available on request.

» Properites

- » High of the protector after crimping: $H=3,3 \text{ mm } \pm 0,1 \text{ mm}^*$
- » Width of the protector after crimping: $W=1,2 \text{ mm } \pm 0,14 / -0,1 \text{ mm}^*$
- » Length of the protector after crimping: $L=30 \text{ mm } \pm 0,5 \text{ mm}^*$
- » Opening angle of the protector before crimping: $\theta=52^\circ \pm 1/-2^\circ^*$
- » Mechanical protection,
- » Flexible laying,
- » Waterproof and hermetic protection,
- » Very short installation time,
- » RoHS compliant,
- » Packing: 150pcs to one carton.

* – Tolerances in accordance with the requirements of TS 0338/96 v3 12.06.2019 Deutsche Telekom AG standard

» Application

- » Fiber Optic Solution
- » Telecommunication, INTERNET
- » CATV, Cable TV, Monitoring
- » Industry
- » LAN, MAN, WAN, FTTx

Series ANT

Aluminium, crimp fiber
optic splice protectors

Fiber optic splice protectors series ANT are applied in nearly all branches of fiber optic engineering. They are used to protect fiber welds in fiber optic splice closures as well as 19" rack fiber optical distribution panels, stand and wall boxes. Small size, tightness of connection and speed of installation are the main advantages of this solution. Excellent climatic and thermal properties make it ideal to use in closed and open spaces. The main goals during the design phase were: full protection of the fiber optic splices, small size after crimping and short installation time. The final products are checked for

compliance with the requirements set out in TS 0338/96 v3 Deutsche Telekom and EN 50411-3-3 European Standard. The sleeves we produce offer full protection to the fiber optic splices. They do not cause additional insertion losses, and they offer protection against mechanical damage, pollution and weather conditions.

Series ANT has small external dimensions (L = 30mm, H = 3.3 mm, W = 1.2 mm).

The protector consists of: a 0.3mm thick aluminum body and 0.3mm thick butyl strips (PIB mass).

This solution allows the use of the protector for fibers with a coating of 250µm or smaller.

The mass strips are made of butyl mass with very good adhesion to many materials and low solubility in water.

Aluminum body reinforcing stiffener connection is made from high quality aluminum strip.

When crimping the protector, the optical fiber is tightly immersed in the mass filling the space between the fiber and the aluminum body. This casing design eliminates air bubbles. It also prevents transverse and longitudinal stresses in the weld splice during the crimping process. Stresses significantly increase the insertion and reflection loss of the connection. In extreme cases, they can lead to breaking the connection, which means repeating the welding procedure. The protector guarantees durability and resistance to crushing, stretching and puncture.

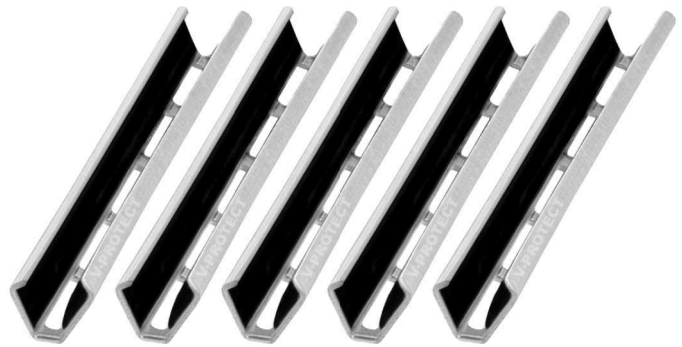

▣ Packing

» Packing: 150 pcs in one paper carton. Each carton contains ten blisters, with 15 protectors per blister. A single is closed with a reusable tape.



References

Protectors meet the requirements of the following standards:

EN 50411-3-3 European standard:

- » Criterion 8.3.1: EN 61300-3-3; Change in attenuation: 1310&1550nm $\delta IL \leq \pm 0,1$ dB per circuit of 5 protected fusion splices
- » Criterion 8.3.3: EN 61300-1-1; Vibration: 10-50Hz, amplitude 0,75mm, 15 cycles, 1550nm $\delta IL \leq \pm 0,2$ dB durin -, $\delta IL \leq \pm 0,1$ dB after - per circuit of 5 protected fusion splices
- » Criterion 8.3.5: EN 61300-2-5, Torsion: magnitude of load 2N, rotation angle +/- 180°, 10 cycles, 1310&1550&1625nm $\delta IL \leq \pm 0,1$ dB after - per circuit of 5 protected fusion splices,
- » Criterion 8.3.6: EN 61300-2-4, Fiber/Cable retention: magnitude of load 2N, 60s, 1 cycle, 1310&1550&1625nm $\delta IL \leq \pm 0,1$ dB after - per circuit of 5 protected fusion splices,
- » Criterion 8.3.7: EN 61300-2-7, Bending: magnitude of load 2N, 5s, 1 cycle, 1310&1550&1625nm $\delta IL \leq \pm 0,1$ dB after - per circuit of 5 protected fusion splices,
- » Criterion 8.3.8: EN 61300-2-17, Cold: -40°C, 96h, 1310&1550nm $\delta IL \leq \pm 0,2$ dB durin -, $\delta IL \leq \pm 0,1$ dB after - per circuit of 5 protected fusion splices
- » Criterion 8.3.9: EN 61300-2-18, Dry heat: +80°C 96h, 1310&1550nm $\delta IL \leq \pm 0,2$ dB durin -, $\delta IL \leq \pm 0,1$ dB after - per circuit of 5 protected fusion splices
- » Criterion 8.3.10: EN 61300-2-19, Damp heat: from +25°C to +55°C, 93%Rh, 4 cycles, 96h 1310&1550nm $\delta IL \leq \pm 0,2$ dB durin -, $\delta IL \leq \pm 0,1$ dB after - per circuit of 5 protected fusion splices
- » Criterion 8.3.11: EN 61300-2-22, Change of temperature: from -40°C to +70°C, 12 cycles, 68h, 1310&1550nm $\delta IL \leq \pm 0,2$ dB durin -, $\delta IL \leq \pm 0,1$ dB after - per circuit of 5 protected fusion splices
- » Criterion 8.3.12: EN 61300-2-26; Salt mist: concentration NaCl 5%, +35°C 96h 6.5÷7.2PH, 1 cycle, 1310&1550&1625nm $\delta IL \leq \pm 0,1$ dB after - per circuit of 5 protected fusion splices, additionally, there are no noticeable significant differences in the appearance of the tested product, such as traces of rust, discoloration, deformation.

TS 0338/96 Deutsche T-COM standard:

- » Criterion 5.8: Transport simulation: from -40°C to +85°C, 20 cycles, 183h,
- » Criterion 5.9.1: TS 0338/96, EN 61300-3-3; Change in attenuation after installation: 1550 $\delta IL \leq \pm 0,1$ dB after - per circuit of 5 protected fusion splices for criterions 5.9.2, 5.9.3, 5.9.4 i 5.9.5 and $\delta IL \leq \pm 0,1$ dB after - per circuit of 12 protected fusion splices for in other tests where the measurement of the change in attenuation is required,
- » Criterion 5.9.2: DIN EN 61300-2-18, Dry heat: +85°C 96h, 1550nm $IL \leq 0,1$ for 5 crimp protectors,
- » Criterion 5.9.3: DIN EN 61300-2-17, Cold: -45°C, 96h, 1550nm $IL \leq 0,1$ for 5 crimp protectors,
- » Criterion 5.9.4: DIN EN 61300-2-19, Damp heat: +40°C, 93%Rh, 96h, 1550nm $IL \leq 0,1$ for 5 crimp protectors,
- » Criterion 5.9.5: DIN EN 61300-2-22, Change of temperature: from -40°C to +70°C, 12 cycles, 68h, 1550nm $IL \leq 0,1$ for 5 crimp protectors,
- » Criterion 5.9.6: EN 60068-2-6 , Vibration: 10-500Hz, 10 cycles, 1550nm $IL \leq 0,1$ for 12 crimp protectors,
- » Criterion 5.9.7: EN 60068-2-27, Shock: 11ms, half sine 15G, 1550nm $IL \leq 0,1$ for 12 crimp protectors,
- » Criterion 5.9.8: TS 0338/96, Tensile strength: magnitude of load 5N, 60s – fiber protrusion $\leq 0,6$ mm, magnitude of load 25N, 60s – fiber protrusion $> 2,5$ mm,
- » Criterion 5.10.2: TS 0338/96, Vertical bending: 6N, deformation of width $\leq +/- 0,2$ mm, deformation of height $\leq +/- 0,5$ mm,
- » Criterion 5.10.3: TS 0338/96, Horizontal bending: 2N deformation of width $\leq +/- 0,2$ mm, deformation of height $\leq +/- 0,5$ mm,
- » Criterion 5.10.4: TS 0338/96, PIB mass control: Pressure force from 200 to 500N, 100s, pressure speed 6mm/min, penetration of the stamp into the PIB mass 0,5mm. Pressure force after test from 50 to 200N.